

High Torque Starter Motors

RAC517

Starter motor direct replacement for Ford Taunus and Cologne engines.

Ford V4 and V6, commonly known as the Taunus (in Germany) and Cologne engines. This unit is a direct replacement for Capri, Granada, Sierra & Scimitar. Strong and powerful, offset gear-reduced starter motor, delivering huge cranking torque through a set of steel internal gears. Lightweight, compact and durable; this unit starts the engine faster with immense power, whilst drawing less current from the battery.

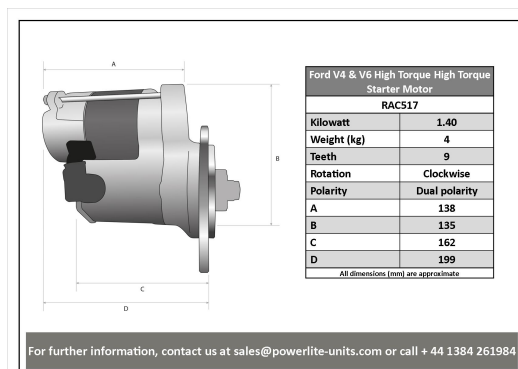
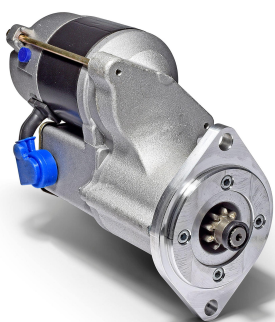

RAC517

Make	Model	Engine Size	Year
Ford	17M	1.7	1967 - 1972
Ford	20M	2.3	1967 - 1972
Ford	26M	2.5	1967 - 1972
Ford	Capri I	2.3	1969 - 1974
Ford	Capri III	2.0	1978 - 1979
Ford	Capri III	2.8	1981 - 1985
Ford	Consul	2.3	1972 - 1975
Ford	Granada II	2.3	1972 - 1985
Ford	Granada II	2.8i	1977 - 1985
Ford	Granada II V6	2.0	1977 - 1985
Ford	Sierra I	2.8i	1982 - 1985
Ford	Sierra I XR4i	2.8	1982 - 1985
Ford	Taunus	2.0	1975 - 1982
Ford	Taunus V6	2.0	1975 - 1982
Ford	Taunus V6	2.3	1975 - 1982
Reliant	Scimitar GTC	2.8	1980 - 1986
Reliant	Scimitar GTE	2.8	1980 - 1986



Made in the UK 

RAC517

Item	Value
Kilowatts	1.40 kW
Teeth	9
Voltage	12 V
Weight	4.00 kg