

High Torque Starter Motors

RAC508A

For Porsche 911 with a G50 gearbox - for standard fitment please see RAC508

Porsche 911 Fits G50 gear box (unit has 10 tooth pinion) Strong, powerful, offset gear-reduced starter motor, delivering huge cranking torque through a set of steel internal gears. Lightweight, compact and durable this unit starts the engine faster with immense power, whilst drawing less current from the battery. For standard fitment please see RAC508

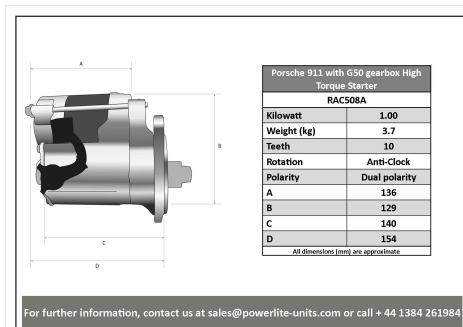
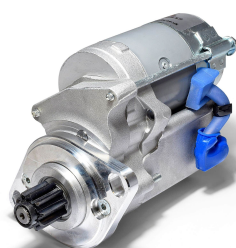
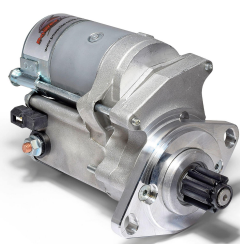

RAC508A

Make	Model	Engine Size	Year
Porsche	911 - 10 teeth G50 gearbox.		1987 - 1989

RAC508A

Item	Value
Kilowatts	1.00 kW
Teeth	10
Voltage	12 V
Weight	3.70 kg