

High Torque Starter Motors

RAC507

Direct replacement for original.

Porsche 924 2.0 normally aspirated engine Strong, powerful, offset gear-reduced starter motor, delivering huge cranking torque through a set of steel internal gears. Lightweight, compact and durable this unit starts the engine faster with immense power, whilst drawing less current from the battery.

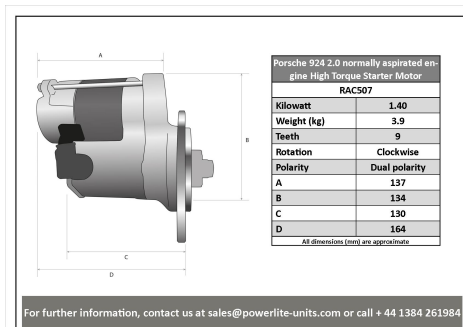
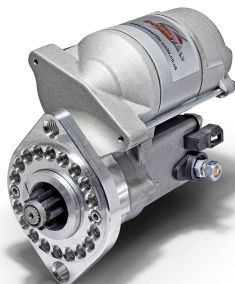
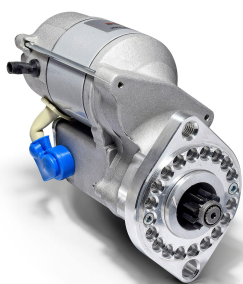

RAC507

Make	Model	Engine Size	Year
Porsche	924	2.0	

RAC507

Item	Value
Kilowatts	1.40 kW
Teeth	9
Voltage	12 V
Weight	3.90 kg