

High Torque Starter Motors

RAC506

This is a counter clockwise unit, for the 924 2.0 normally aspirated application see part no. RAC507

Porsche 924 2.0 Turbo, 924 2.5S, 944 Strong, powerful, offset gear-reduced starter motor, delivering huge cranking torque through a set of steel internal gears. Lightweight, compact and durable this unit starts the engine faster with immense power, whilst drawing less current from the battery.

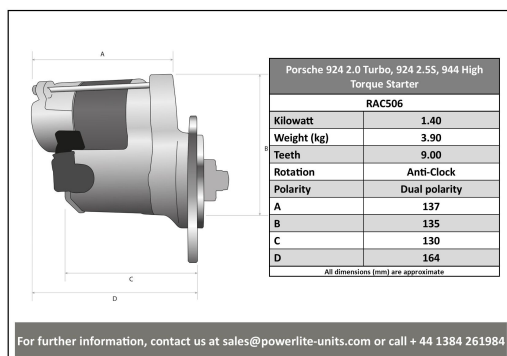
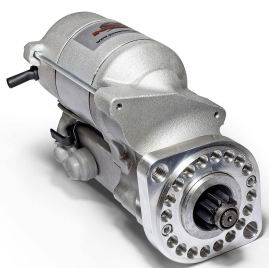

RAC506

Make	Model	Engine Size	Year
Porsche	924	2.0 Turbo	
Porsche	924	2.5S	
Porsche	944	2.5	
Porsche	944	2.5 Turbo	
Porsche	944	2.7	
Porsche	944	3.0 S2	

RAC506

Item	Value
Kilowatts	1.40 kW
Teeth	9
Voltage	12 V
Weight	3.90 kg