

High Torque Starter Motors

RAC500

Direct replacement for original on Ford Cross Flow, Pre Cross Flow and Kent engines. Suitable for 110T ring gear only.
WARNING FORD: Check you have the correct fitment.

Ford Kent, Cross Flow and Pre Cross Flow engines using a 110 teeth ring gear Strong, powerful, offset gear-reduced starter motor, delivering huge cranking torque through a set of steel internal gears. Lightweight, compact and durable this unit starts the engine faster with immense power, whilst drawing less current from the battery.

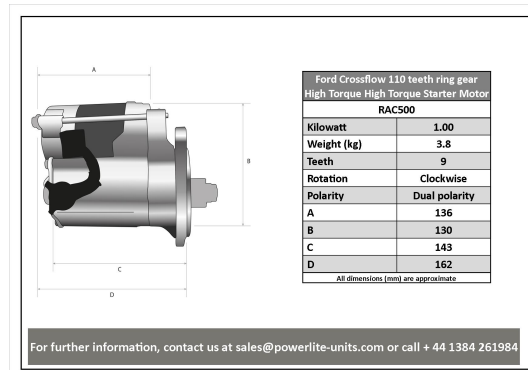
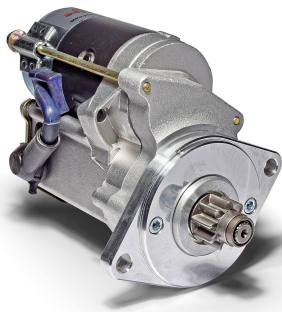

RAC500

Make	Model	Engine Size	Year
Ford	Kent X-flow		
Ford	Pre X-flow		
Ford	Capri MK1	1300	1969 - 1974
Ford	Capri MK1	1600	1969 - 1974
Ford	Capri MK2	1300	1974 - 1978
Ford	Capri MK2	1600	1974 - 1978
Ford	Capri MK3	1300	1978 - 1986
Ford	Escort MK1	1100	1967 - 1975
Ford	Escort MK1	1300	1967 - 1975
Ford	Escort MK1	1600	1967 - 1975
Ford	Escort MK2	1100	1974 - 1980
Ford	Escort MK2	1300	1974 - 1980
Ford	Escort MK2	1600	1974 - 1980
TVR	Ford X-flow engine		



Made in the UK 

RAC500

Item	Value
Kilowatts	1.00 kW
Teeth	9
Voltage	12 V
Weight	3.80 kg