

High Torque Starter Motors

RAC407

Ford V4 and V6, commonly known as the Essex engine. Direct Replacement for original starter.

Ford Essex V4, Ford Essex V6 In Capri, Cortina, Corsair etc Strong, powerful, offset gear-reduced starter motor, delivering huge cranking torque through a set of steel internal gears. Lightweight, compact and durable this unit starts the engine faster with immense power, whilst drawing less current from the battery.

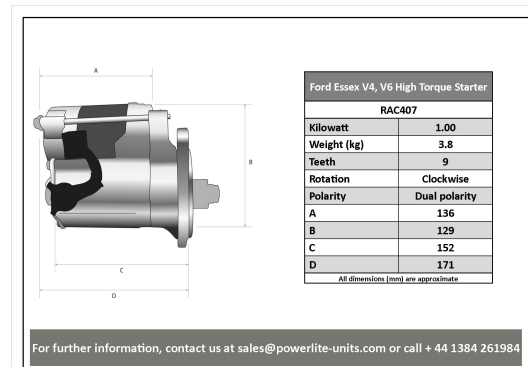
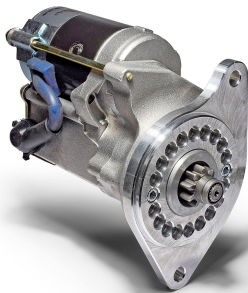

RAC407

Make	Model	Engine Size	Year
AC	ME3000	3.0L V6	1979 - 1985
Ford	A Series trucks	3.0L V6	1973 - 1985
Ford	Capri	2.0L V4	1974
Ford	Capri	3.0L & 3.1L V6	1974 - 1978
Ford	Capri 2000GT	2.0L V4	1969
Ford	Consul	2.0L V4	1972 - 1974
Ford	Consul (Granada MK1 based)	2.5L & 3.0L V6	1972 - 1975
Ford	Corsair	1.7L & 2.0L V4	1965
Ford	Corsair	1.7L V4	1968
Ford	Corsair	2.0L V4	1970
Ford	Granada	2.5L & 3.0L V6	1972 - 1976
Ford	Transit	1.7L & 2.0L V4	1965
Ford	Transit	1.7L V4	1975
Ford	Transit	2.0L V4	1978
Ford	Transit (emergency services)	3.0L V6	1965 - 1977
Ford	Zephyr	2.5L & 3.0L V6	1966 - 1972
Ford	Zephyr Four	2.0L V4	1971
Ford	Zephyr Four MK4	2.0L V4	1966
Ford	Zodiac	2.5L & 3.0L V6	1966 - 1972



Made in the UK 

RAC407

Make	Model	Engine Size	Year
Ford	Essex V4		
Ford	Essex V6		
Gilbern	Genie	2.5L & 3.0L V6	1966 - 1979
Gilbern	Invader	3.0L V6	1969 - 1973
Marcos	Marcos various models	3.0L V6	Up to 1971
Reliant	Scimitar	2.5L & 3.0L V6	1966 - 1970
TVR	Essex V6		
TVR	3000M	3.0L V6	1972 - 1979
TVR	3000S	3.0L V6	1972 - 1979
TVR	Taimar	3.0L V6	1972 - 1979
TVR	Tuscan V6	3.0L V6	1969 - 1971

RAC407

Item	Value
Kilowatts	1.00 kW
Teeth	9
Voltage	12 V
Weight	3.80 kg